

Type BC

Electrically driven reciprocating pump

BC double acting piston pumps for bilge, oily bilge, boiler feed, hydrophore and other water supply service. Max. discharge head is 14 bar. Temperature up to 100 °C.

- The pumps have bevelled precision gears running in closed crankcase with oil bath.
- The pumps are silent running with steady operation, as the piston moves through an eccentric.
- The pumps are fully tested with motor drive. Certificates from any of the classification societies can be issued.

Standard Specification

PUMP HOUSING:

Hard, close-grained cast iron or bronze.

AIR VESSEL:

Cast iron or bronze.

CRANK-CASE:

Crank-case and column in cast iron integral casted.

PISTON ROD:

Stainless steel.

CYLINDER SLEEVE:

Renewable sleeve of copper.

PUMP VALVES:

Stainless suction and discharge valves on a common valve intermediate plate of cast iron or bronze.

PUMP PISTON:

Bronze or cast iron fitted with rings of synthetic rubber.

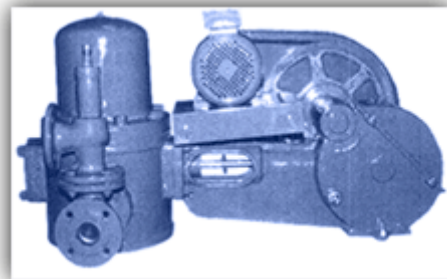

STUFFING BOX:

Stuffing box of bronze, fitted with U-cup packing rings.

FITTINGS:

Adjustable motor support, "V"-belt drive, guard for "V"-belt drive, relief valve, air cock, drain plugs and oil level indicator.

NOTE:

A name plate is fixed to all pumps, indicating size and production number etc.

Type BC

Electrically driven piston pump

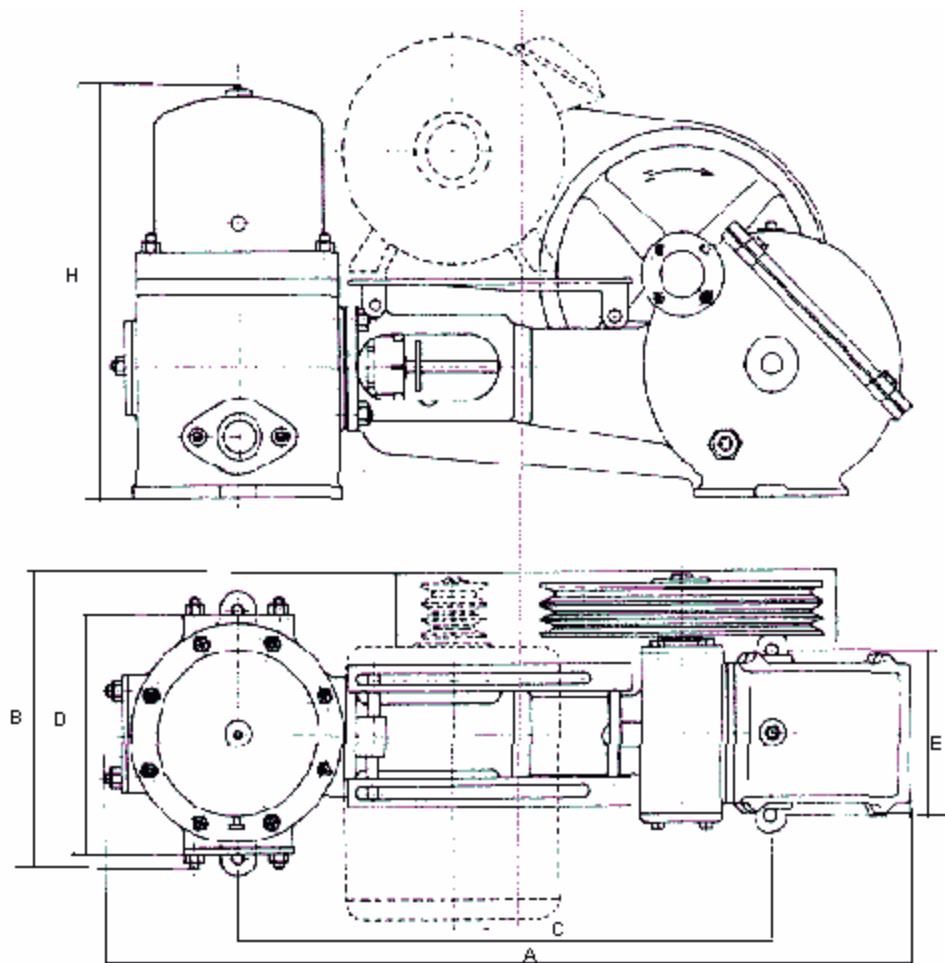

Type	Cyl.	Stroke mm	Suction & discharge pipe	Overall length A mm	Overall height H mm	Overall width B mm	C mm	D mm	E mm	Weight excl. motor kg
T 2	□	40	1"PT	600	340	240	395	185	112	45
T 4	□	65	1¼"PT	900	475	325	585	220	175	100
T 5	∅	80	∅50	1230	650	440	820	420	210	280
T 5A	∅	115	∅50	1330	870	500	820	475	210	350
T 6	∅	115	∅50	1500	870	550	980	475	270	400
T 6A	∅	170	∅80 ∅100	1500	870	550	980	475	270	470

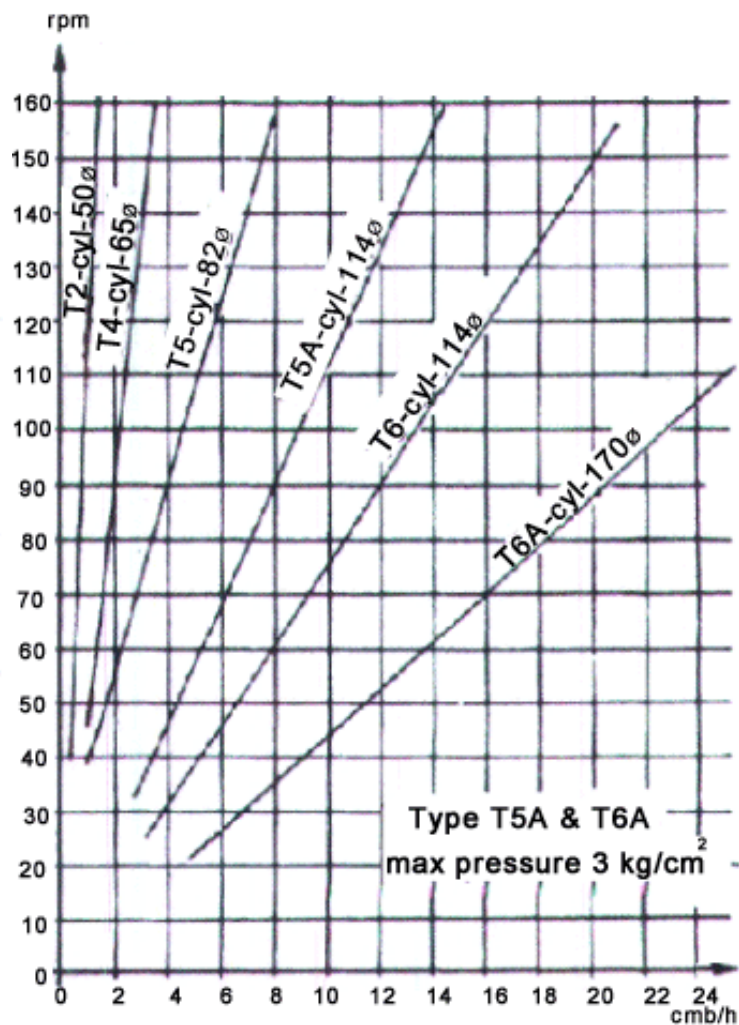
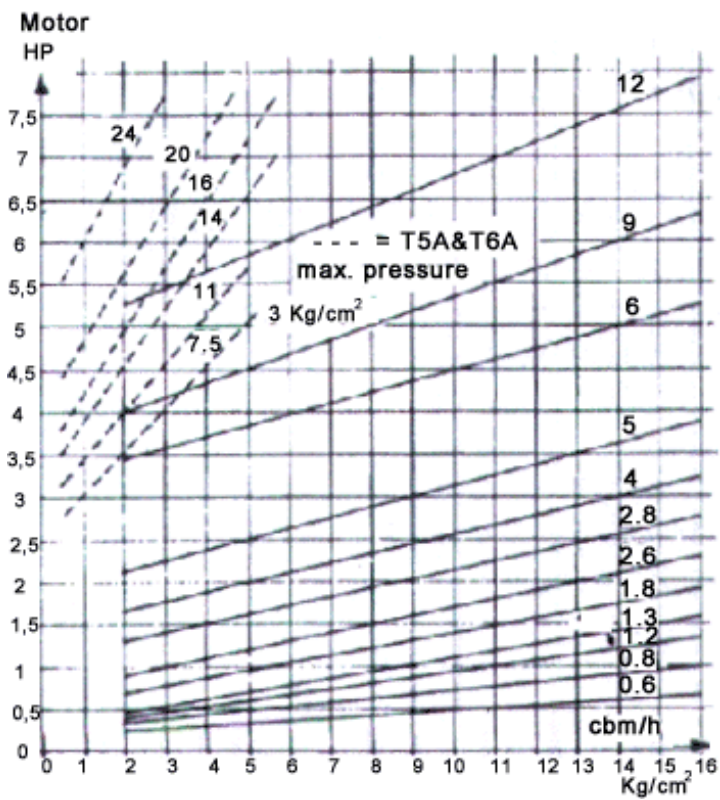

IRON Pump A/S
 Generatorvej 10
 DK-2730 Herlev

Phone: +45 44916788
 Fax: +45 44911644

Web: www.ironpump.dk
 e-mail: salg@ironpump.dk

