

Reversible propeller pump

Introducing the QTe, the 4th generation of
world class Anti Heeling pumps

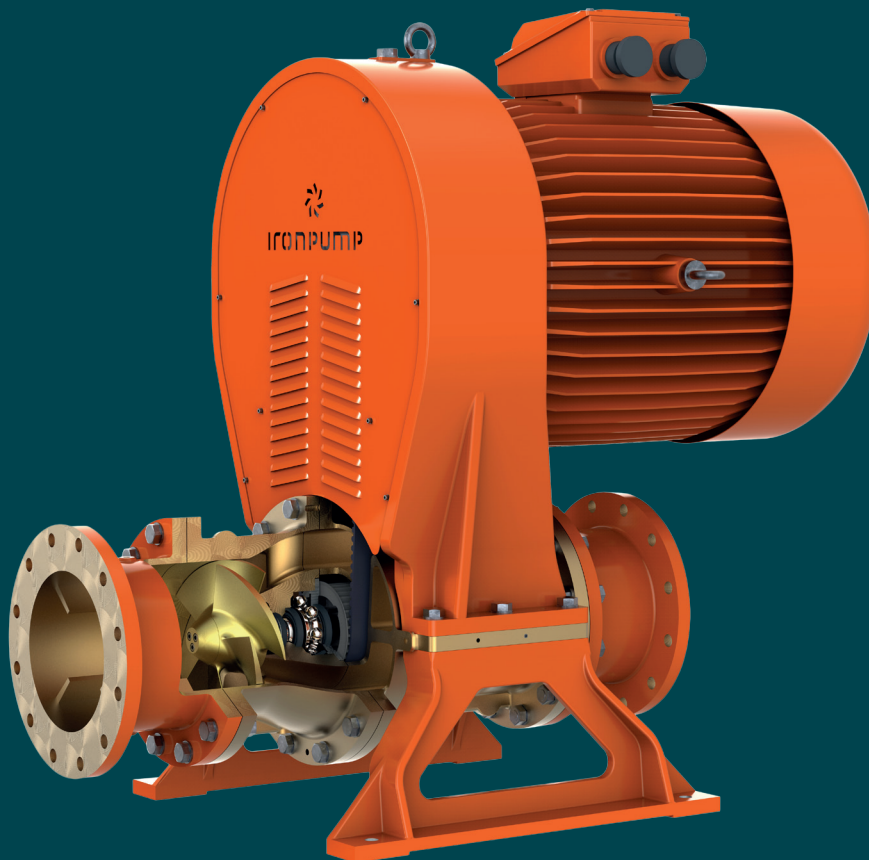

- Flow from 250 up to 1600 m³
- Reversible operation
- Easy to service
- Compact design with a small footprint
- Reduced demand for service space
- For both sea and fresh water service
- Standard electric motor



IRONPUMP

world class water pumps

Applications

The IRON Pump A/S propeller pump series QTe is primarily operating on heeling duties with large capacities, low heads and two-way operations. Other applications, such as condenser cooling services are also mastered by the QTe series.

Options

- Flanges configuration available in DIN, ANSI and JIS.
- Service-kits, consisting of belt, bearings, seals and gaskets.
- Venting device for removing air inside the pump.

Advantages

The simple design not only provides a rigid and robust construction but also facilitates quick inspection and service. The wide use of standard components ensures reduced cost on spare parts.

Easy. The compact in-line design allows for easy service and for installation in narrow spaces, like in between the frames or stringers.

Low Risk. The belt drive design results in a compact pump with low risk and low cost operation, throughout the pump's entire lifespan. In the event that a mechanical seal fails, the pump can easily be repaired and up and running again in no time with as little as a

service kit. The entire pump can be serviced leaving the the main installation or motor untouched.

Efficiency. All standard motors can be mounted in order to achieve best possible efficiency and accommodate customer demands and preferred brands. Motors can be supplied for, and delivered with, frequency converters for further improvements.

Flexible. QTe pumps offer large flow and low head as the application demands. Contrary to many other propeller pumps, the QTe series can be geared to fit the required operational requirements, thanks to the pump drive design.

History

Since IRON Pump A/S first pioneered the anti heeling pump back in 1952 the company has supplied several thousand anti heeling pumps for all manners of heeling operations and applications, setting the tone for both quality, reliability and flexibility in the market and can be found today on most types of vessels throughout the world.

The unique design of the QT pump series has proven its worth with reliability and flexibility, and those values prevail with the QTe.

International Patent Application No. PCT/DK2013/050247 – Chinese Patent Application No. 201380062859.9

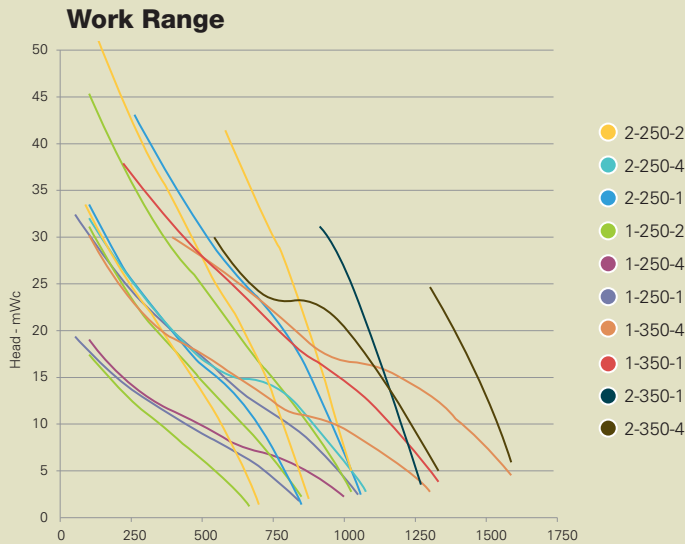

Overall Dimensions (with maximum size motor)

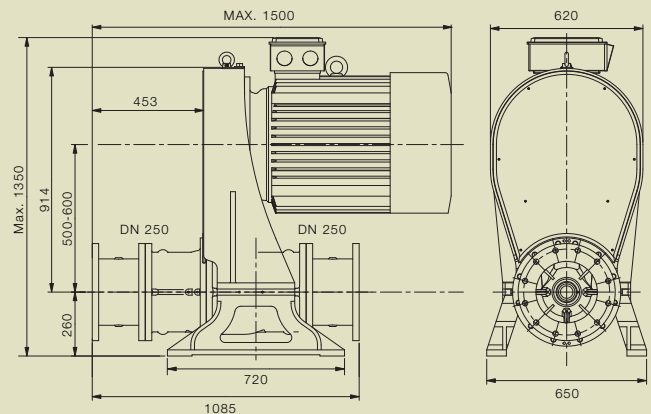

IRON PUMP A/S has designed, developed and produced pumps for more than 100 years. We supply a wide range of high quality pumps, all able to be individually adapted and customized to meet client demands.

Every pump is assembled and tested at our in-house production and test facility to ensure quality. They can all be delivered with the most common certification regarding use in marine applications, as well as for material-environment- and quality assurance.

